

ExtraCut

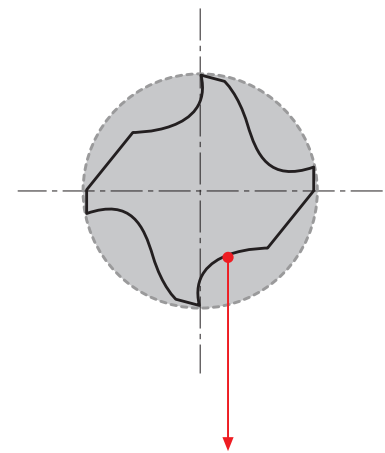
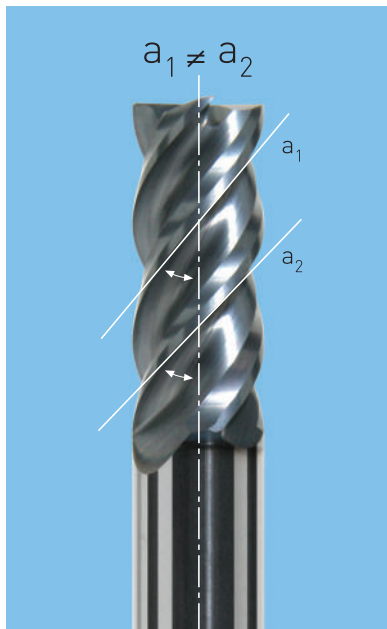

Improved chip disposal with the special flutes geometry and the irregular helix angle.

Anti-vibration end mills

Helix Tools has started to produce a new generation of EC and ECS series anti-vibration tools. The EC and ECS series use a new flute geometry that improves chip disposal properties. They also use irregular pitch flutes in combination with varied helix angles that significantly reduces the occurrence of vibration when machining, leading to higher reliability and smoother surface finishes. Due to these advantages and use of the new coating technology they can be used effectively for machining difficult to cut materials. They have two times tool life than the other standart types.

EC404

Solid Carbide End Mills, ExtraCut

Application Range

HELIX TOOLS

- Unalloyed Steels
- Machining Steels
- Low Alloy Steels
- Stainless Steels
- Heat Resistant Materials
- Titanium and Titanium Alloys
- Cast Iron
- Hardened Materials
- Aluminium Alloys
- Copper and Copper Alloys
- Plastics
- Graphite

A

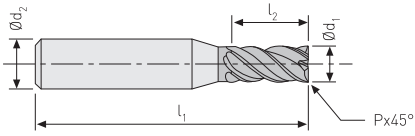

B

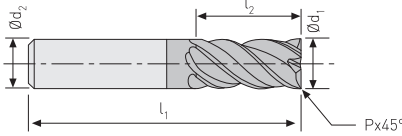

Order Code	d _{1 mm} h10	l _{1 mm}	l _{2 mm}	d _{2 mm} h6	z	P	Type
EC404-0300 ATN	3	50	8	6	4	0.10x45°	A
EC404-0400 ATN	4	50	10	6	4	0.15x45°	A
EC404-0500 ATN	5	50	13	6	4	0.15x45°	A
EC404-0600 ATN	6	57	14	6	4	0.20x45°	B
EC404-0800 ATN	8	63	19	8	4	0.20x45°	B
EC404-1000 ATN	10	72	22	10	4	0.25x45°	B
EC404-1200 ATN	12	83	26	12	4	0.25x45°	B
EC404-1400 ATN	14	83	26	14	4	0.40x45°	B
EC404-1600 ATN	16	92	32	16	4	0.40x45°	B
EC404-1800 ATN	18	92	32	18	4	0.50x45°	B
EC404-2000 ATN	20	104	38	20	4	0.50x45°	B



EC414

Solid Carbide End Mills, ExtraCut, With Weldon Shank

Application Range

HELIX TOOLS

- Unalloyed Steels
- Machining Steels
- Low Alloy Steels
- Stainless Steels
- Heat Resistant Materials
- Titanium and Titanium Alloys
- Cast Iron
- Hardened Materials
- Aluminium Alloys
- Copper and Copper Alloys
- Plastics
- Graphite

A

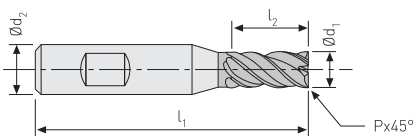

B

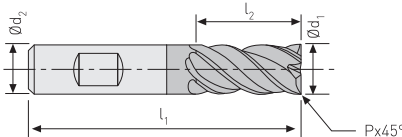

Order Code	d _{1 mm} h10	l _{1 mm}	l _{2 mm}	d _{2 mm} h6	z	P	Type
EC414-0300 ATN	3	50	8	6	4	0.10x45°	A
EC414-0400 ATN	4	50	10	6	4	0.15x45°	A
EC414-0500 ATN	5	50	13	6	4	0.15x45°	A
EC414-0600 ATN	6	57	14	6	4	0.20x45°	B
EC414-0800 ATN	8	63	19	8	4	0.20x45°	B
EC414-1000 ATN	10	72	22	10	4	0.25x45°	B
EC414-1200 ATN	12	83	26	12	4	0.25x45°	B
EC414-1400 ATN	14	83	26	14	4	0.40x45°	B
EC414-1600 ATN	16	92	32	16	4	0.40x45°	B
EC414-1800 ATN	18	92	32	18	4	0.50x45°	B
EC414-2000 ATN	20	104	38	20	4	0.50x45°	B

